

User Guide Raid Harness/Belt



Conforms to
EN813:2008, EN12277-C:2015 & EN358:1999

sar-products.com
+44 (0) 161 621 0309
sales@sar-products.com

User Guide Raid Harness/Belt



Std:	QC:
Serial No.:	

CE0598

sar-products.com
+44 (0) 161 621 0309
sales@sar-products.com

Product Record

This documentation should be issued with and kept for each item or system. Please see the product label for the details required below. Consult this guide for advice on inspection, maintenance, lifespan, etc.

User's Name:		Date Of Purchase:	
Date Of Manufacture:		Product Serial No.:	
Date First Used:		Inspection Record	
Date	Reason for entry: Periodic examination or repair	Name of Inspector	Next date of Inspection

Declaration Of Conformity

The EU Declaration of conformity is available by scanning the QR code or visiting - www.sar-products.com/eu-doc/



Certificate Of Conformity

We certify that the Raid Harness when fully assembled as a unit, conforms to EN813:2008 & EN12277-C:2015. The Raid belt conforms to EN358:1999 if manufactured with a restraint point. The Raid Belt & Harness are rated to 150kg. Other components used with this product must conform to the relevant EN standards.

Signature For SAR Products Ltd

Specialist Access & Rescue Products Ltd.
Sarena House, Vulcan Street, Oldham, OL1 4LQ
T: +44 (0)161 621 0309 E: sales@sar-products.com W: www.sar-products.com

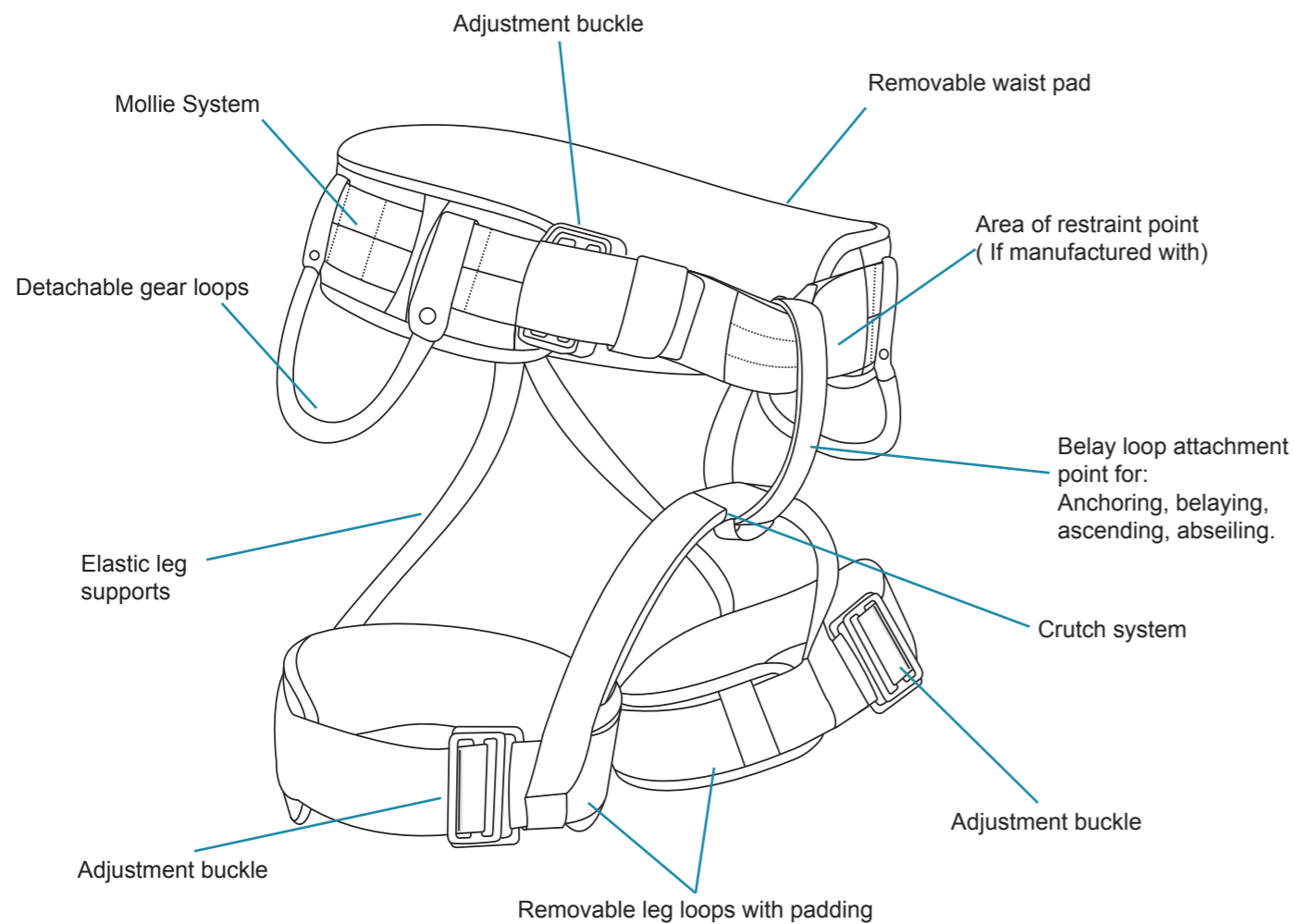

Raid Harness

The Raid harness when fully assembled as a unit, conforms to EN813:2008 & EN12277-C:2015 The Raid belt conforms to EN358:1999 if manufactured with a restraint point. Conforms to EN361 when used with any of our chest harness range & Link Sling.

Important:

Please read, study and understand these instructions before use. THE MATERIALS USED IN THIS PRODUCT ARE HIGH SPEC POLYESTERS.

Use:

This harness has been designed for your protection and therefore are (PPE) personal protective equipment. They are sit harnesses for climbing, mountaineering, rescue, intervention and technical access (in normal climatic conditions). They are suitable for many other applications but please check with the manufacturer first. Use only as instructed and with compatible items of equipment. These should conform to the relevant European standards or those your country follows. Check that the safe function of any one component within a system will not interfere with the safe function of another. Twists in the webbing and buckles fastened incorrectly, can cause problems, weakness, serious injury or death. Neatness is strength. Users should be trained, competent or under the supervision of such a person. Before use in a safe environment, move around and hang in the harness from the tie-in points to verify that the harness is comfortable and properly adjusted.

The user should satisfy their self that they do not suffer from any medical condition which could affect their own safety whilst using this equipment normally and in a rescue. A rescue plan should be in place before using this equipment.

Note: The information in this guide meets the requirements of the PPE EU Regulations 2016/425. It is not comprehensive and cannot be substituted for the correct training, which can be provided if required. If in any doubt please don't hesitate to contact us.

Safety:

The safety provided by these harnesses depends on their strength and skill of the user. The strength will be reduced through age, wear and tear, abrasion, cuts, high impact loads, tight/sharp edges, knots, some chemicals (e.g. alkalis, etc.), UV or failure to store and maintain as recommended. This list is not exhaustive. The SAR harnesses have a high strength rating and will help against the above however, there are exceptions, which include chemical attack or very high temperatures, wet and icy conditions make harness straps are more difficult to adjust. Do not alter the product in any way. Any harness subjected to a minor fall should be examined and discarded if there is any sign of defect or any doubts about its safety. This harness is not suitable for fall arrest purposes. Users must be medically fit for activities at height.

WARNING: inert suspension in a harness can result in serious injury or death.

Lifespan:

This is difficult to estimate but we advise as follows:

Do not use more than ten years after the date of manufacture. Assuming you have used the correct storage. The working life can vary between a single use in extreme circumstances (e.g. highly chemical environment, serious fall) to the maximum of ten years, depending on how the product is used. The working life will be reduced through age, general wear and tear, abrasion, cuts, damage to component parts, inappropriate ancillary equipment, high impact load, prolonged exposure to UV light including sunlight, elevated temperature (50°C max) exposure to some chemicals (e.g. alkalis, etc.) or failure to store and maintain as recommended. This list is not exhaustive.

Inspection:

Before each use visually inspect to ensure the product is in serviceable condition and operates correctly. An examination should be carried out at least every 6 months by a competent person authorised by the manufacturer. These inspections should be recorded paying particular attention to areas of potentially high wear such as attachment points, buckles, connectors and sewn joints.

Inspect as follows:

Textiles: Check for cuts, tears, and abrasions, damage due to deterioration, contact with heat, alkalis or other corrosives.

Sewing: Check for broken, cut or worn threads.

Metals: Check for cracks, distortion, corrosion, wear by abrasion, burrs, worn or loose rivets or screws, discolouration caused by extreme heat (greater than 100°C) broken springs, frays or cuts, seizure of moving parts, broken or missing components.

Immediately withdraw from service any items showing defects. The user's life depends on it. All repair work should be carried out by the manufacturer or with their authorisation.

Anchorage & Fall Distance:

Anchor points should always be strong enough to hold the user particularly in the event of a fall. They should be at least 15kN. A webbing lanyard or rope should be

effectively sleeved to protect against damage if structural members with sharp edges cannot be avoided as anchorage points. Anchor points, wherever possible, should be above the user to limit any fall to less than the length of the safety line or lanyard. Distance of a possible fall should be considered so as to keep clear of contact with ground or other objects below the work place. Check all user manuals of all ancillary equipment used.

Maintenance:

Always keep the product clean and dry. Any excess moisture should be removed with a clean cloth and then allowed to dry naturally in a warm room away from direct heat.

Cleaning:

Rinse in clean cold water. If still soiled wash in clean warm water (max. 40°C) with pure soap or a mild detergent (within pH range of 5.5 to 8.5) You can use a washing machine but first place the product in a suitable bag to protect against mechanical damage. Rinse properly in clean cold water, dry in a well aired area. NOT IN DIRECT SUNLIGHT OR WITH HEATERS.

Chemicals:

Avoid contact with any chemicals which could affect the performance of the product. If contact occurs or is suspected then discard the product immediately. If used in a marine environment thoroughly rinse in clean cold water and dry after each use.

Storage:

After cleaning, store unpacked in a cool, dry, dark place away from excessive heat sources or other possible causes of damage. Do not store wet. If a long shelf life is required it is advisable to store in a moisture proof package (e.g. polythene bag).

Warning:

Climbing or Working at height is hazardous. It is the user's responsibility to ensure understanding of the correct and safe use of this equipment, to use it only for the purposes for which it is designed and to practise all proper safety procedures. Lanyards when used in conjunction with a belt be maintained at or above waist level and be kept taut; and free from movement is restricted to a maximum of 0,6m.

Meanings Of Markings:

- The name, trademark or any other means of identification provided by the manufacturer or supplier.
- The batch or serial number
- The year of manufacture
- CE... EC logo followed by the number of the notified body
- EN... European standard attributed to this PPE
- Product description and/or reference
- Evaluation of capacity in Kg
- Size

Strengths quoted are when the product is tested new and are in accordance with the manufacturer's test methods or to the appropriate standard. Any weights and measurements are approximate.

Nothing in this document affects the consumer's statutory rights.

Notified Body:

SGS FIMKO OY, Takomotie 8, FI-00380 Helsinki, Finland.
Notified Body No: 0598

Specifications - Raid Harness/Belt:

- Fully adjustable waist and legs
- Wrap around or step in fitting
- Well-established, easy interlocking buckling system
- Laminated, high quality, sandwiched closed cell foam padding
- High quality polyester webbing, with hidden locking stitch
- Removable gear loops
- Standard Waist Size: 85cm to 112cm
- Standard Leg/Thigh Size: 50cm to 74cm
- Working Load Limit: 150kg.

Weight of full harness system:

- Standard Harness: 900g
- QC Harness: 1026g

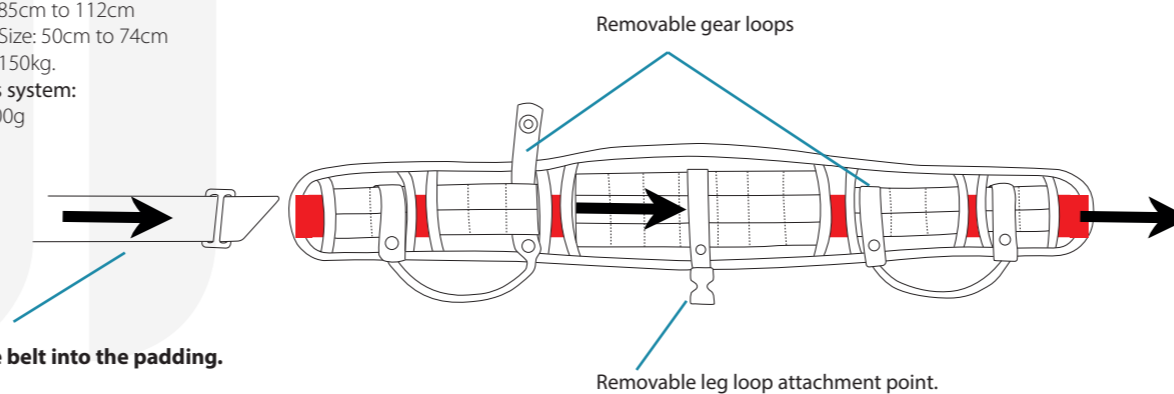

When threading the belt into the padding.

Fitting Instructions:

Note: the following instructions are to fit the harness as it was designed so that chemicals or mud etc. would not soil it from your footwear. However you can still fit the harness as a step in type without disconnecting the waist and leg buckles by stepping into the harness and adjusting the buckles.

1. Open the harness out and check there are no twists and it is following the lines of its design.
2. Place around waist and hold in position on waist using your inner arms/elbows. Fig. 1.
3. Bend forward and pull belay loop up through your legs using your right hand still holding waist in position. Fig. 2.
4. Position belay loop over waist belt buckle and fit into position around belt using 3 bar thread buckle. Figs. 3 & 4
5. Fit waist buckle as shown in Figs. A to D. centralising position of belay to your body and adjusting to fit comfortably on waist. Fig. 5.
6. Fit each leg firmly around upper thigh and lock. Fig. 6.
7. Once the harness is fitted check all is correct and there are no twists, all buckles are locked correct and secured back through elastic ties, the belay loop is around waist belt and waist pad and belay loop are central. Figs. 7.

IMPORTANT:

Ask a partner to do a BUDDY check on your harness, equipment and set systems prior to use.

Tying into the belt and crutch system using a figure of 8 knot.

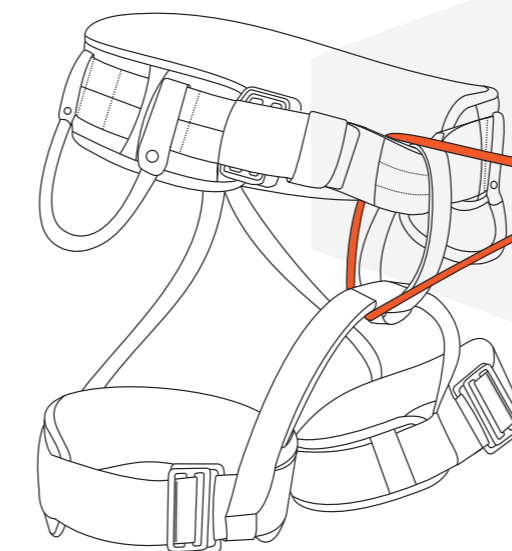

WARNING: No other part of the harness should be tied into.

Fig. 1

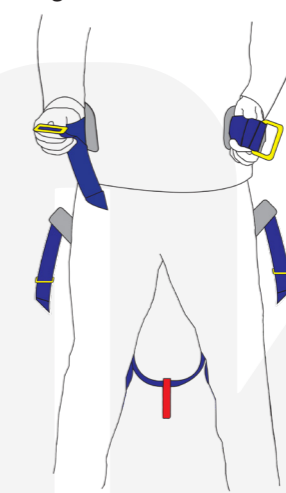

Fig. 2

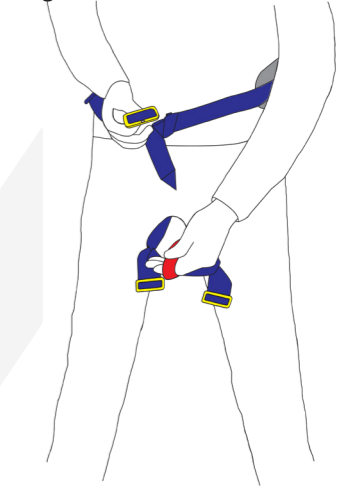

Fig. 3

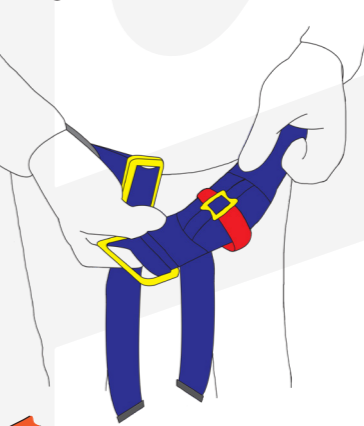

Fig. 4

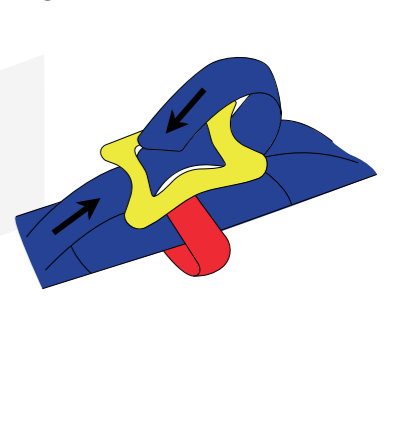

Fig. 5

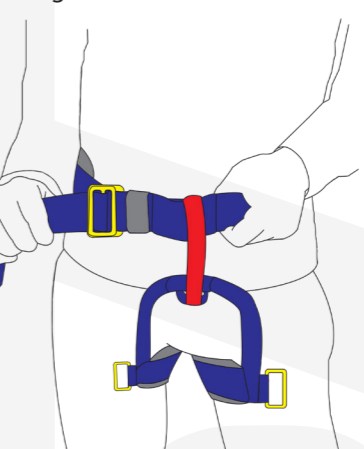

Fig. 6

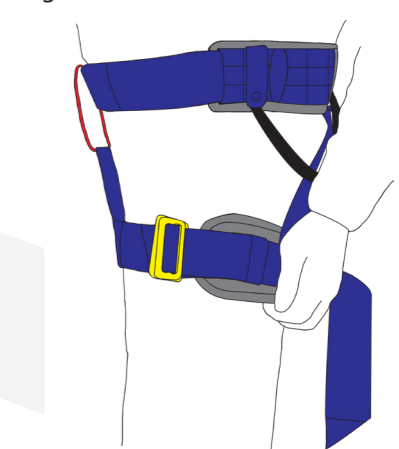

Fig. 7

