

- there are many hazards that may affect the performance of the equipment and corresponding safety precautions that have to be observed during equipment utilization, especially:
 - trailing or looping of lanyards or lifelines over sharp edges,
 - any defects like cutting, abrasion, corrosion,
 - climatic exposure,
 - pendulum falls,
 - extremes of temperature,
 - chemical reagents,
 - electrical conductivity.
- personal protective equipment must be transported in the package (e.g.: bag made of moisture-proof textile or foil bag or cases made of steel or plastic) to protect it against damage or moisture.
- the equipment can be cleaned without causing adverse effect on the materials in the manufacture of the equipment. For textile products use mild detergents for delicate fabrics, wash by hand or in a machine and rinse in water. Plastic parts can be cleaned only with water. When the equipment becomes wet, either from being in use or when due cleaning, it shall be allowed to dry naturally, and shall be kept away from direct heat. In metallic products some mechanic parts (spring, pin, hinge, etc.) can be regularly slightly lubricated to ensure better operation. Other maintenance and cleaning procedures should be adhered to detailed instructions stated in the manual of the equipment.
- personal protective equipment should be stored loosely packed, in a well-ventilated place, protected from direct light, ultraviolet degradation, damp environment, sharp edges, extreme temperatures and corrosive or aggressive substances.

IT IS THE RESPONSIBILITY OF THE USER ORGANISATION TO PROVIDE THE IDENTITY CARD AND TO FILL IN THE DETAILS REQUIRED.

THE IDENTITY CARD SHOULD BE FILLED IN BEFORE THE FIRST USE BY A COMPETENT PERSON, RESPONSIBLE IN THE USER ORGANIZATION FOR PROTECTIVE EQUIPMENT.

ANY INFORMATION ABOUT THE EQUIPMENT LIKE PERIODIC INSPECTIONS, REPAIRS, REASONS OF EQUIPMENT'S WITHDRAWN FROM USE SHALL BE NOTED INTO THE IDENTITY CARD BY A COMPETENT PERSON.

THE IDENTITY CARD SHOULD BE STORED DURING A WHOLE PERIOD OF EQUIPMENT UTILIZATION.

DO NOT USE THE EQUIPMENT WITHOUT THE IDENTITY CARD.

ALL RECORDS IN THE IDENTITY CARD CAN BE FILLED IN ONLY BY A COMPETENT PERSON.

IDENTITY CARD

MODEL AND TYPE OF EQUIPMENT

REF. NUMBER

SERIAL NUMBER

DATE OF MANUF.

USER NAME

DATE OF PUTTING INTO OPERATION

DATE OF PURCHASE

PERIODIC EXAMINATION AND REPAIR HISTORY

	DATE	REASON FOR ENTRY PERIODIC EXAMINATION OR REPAIR	DEFECTS NOTED, REPAIRS CARRIED OUT AND OTHER RELEVANT INFORMATIONS	NAME AND SIGNATURE OF COMPETENT PERSON	PERIODIC EXAMINATION NEXT DUE DATE
1					
2					
3					
4					

EC type examination carried out by CETE APAVE SUDEUROPE, BP 193, 13322 Marseille, France - 0082

Manufacturer:
EYECATCHER BV, Candelastraat 2, 2441 LR Nieuwveen, The Netherlands
tel. +31 172 575 570 - www.eyecatchersafety.com

Instruction Manual



Read and understand the manual before using the equipment

Roofing Anchor Point AT403

In accordance with 5.3.2; 5.3.3; 5.3.4 of EN 795:2012

Roofing anchor point AT 403 is an anchor point to be used on wooden inclined roofs. This anchor point conforms to EN 795:2012 type A within own strength and strength of connection to a wooden structure. It is used for connecting a fall arrest system (e.g. energy absorber to lanyards, fall arresters, cables of fall arresters) on horizontal prestressed concrete slabs pursuant to Directive of the European Parliament 2001/45/EC. The device is suitable for protection of only one person.

DESIGN

The device comprises two metal sheet plates connected by a hinge with bracket which is an anchor point for personal protection equipment.

MARKING OF THE DEVICE

- marking of the manufacturer

AT403 - reference no.

Testet tu p. 5.3.3;5.3.2;5.3.4 of EN 795:2012/A - conformity with a relevant standard

- note: read the manual before using the equipment

max. 1 x — admissible number of persons protected by AT403

mm/yyyy - manufacturing date

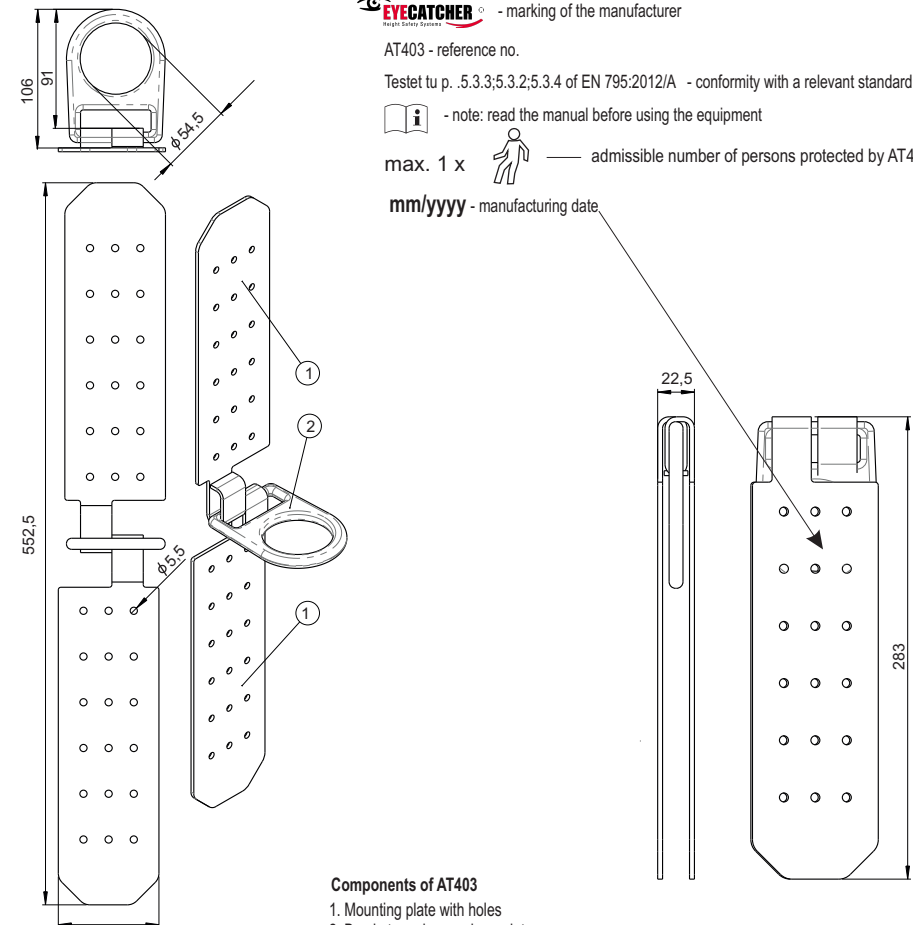

Components of AT403

1. Mounting plate with holes
2. Bracket used as anchor point

TIME OF USAGE - The anchor point can be used for 5 years from the date of the first use. Following the first five years of usage the manufacturer's inspection must be carried out.

The inspection can be carried out by:

- the anchor point manufacturer;
- person authorized by the manufacturer;
- company authorized by the manufacturer.

During the manufacturer's inspection time of usage of the device until the next inspection shall be arranged. The point must be withdrawn from use immediately and destroyed if it has been used to arrest a fall.

INSTALLING THE DEVICE

The device should be fixed to a wooden structure with nails or wood screws with diameter of 4 mm and length of min. 70 mm. When the device is fixed with nails place them in min. 32 holes in the mounting plates arranged evenly with 16 pieces per each plate. When the device is fixed with wood screws place them in min. 28 holes in the mounting plates arranged evenly with 14 pieces per each plate.

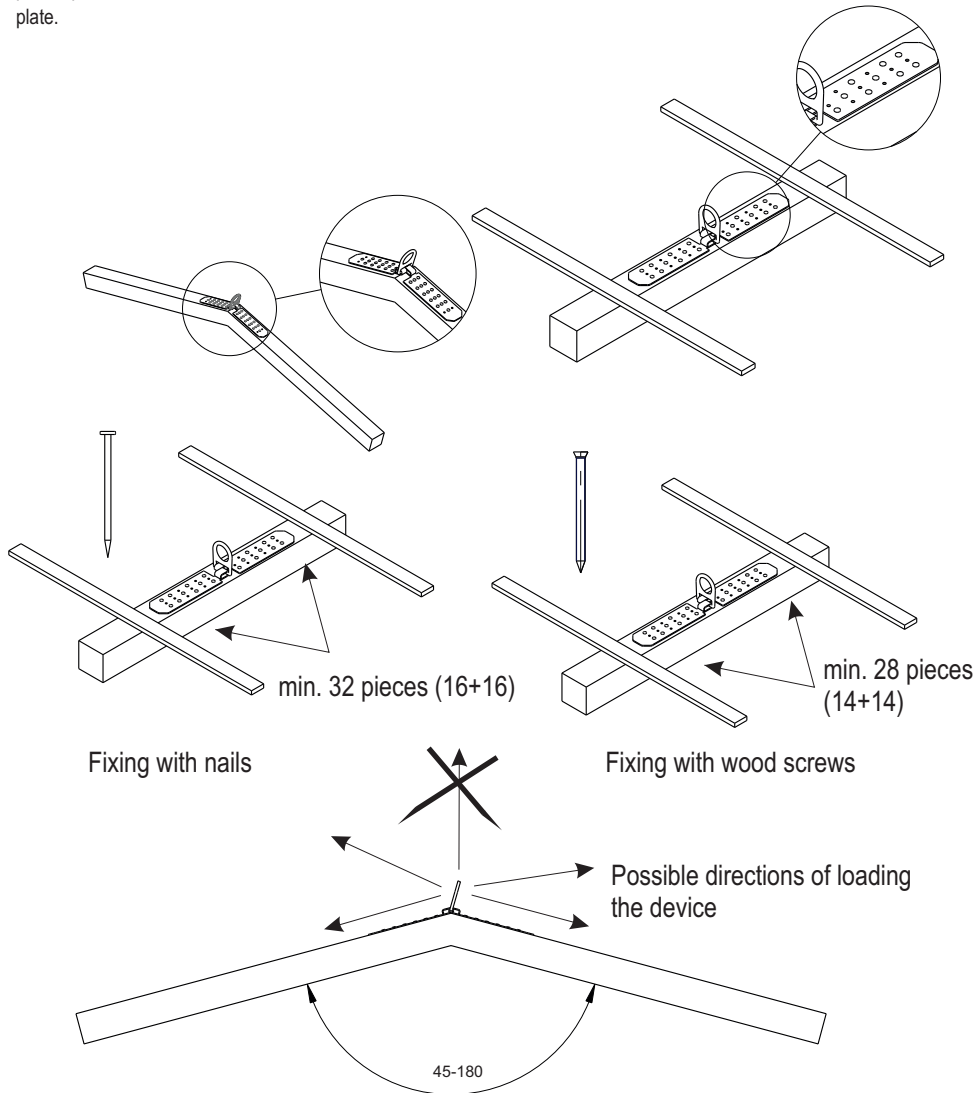

The device AT 403 can be installed only on wooden beams with dimensions of no less than 70x70 mm.

Minimal static strength of a structural anchor point must be 12 kN.

Connect only one device suitable to operate horizontally compliant with EN 353-2, EN 358 or EN 360 to the fixed device in accordance with instruction manuals of these devices for such combination.

The user must take into account the risk of injuries when arresting a fall beyond the edge. Special rescue procedures should be introduced and adequate trainings conducted including possibility of a potential fall beyond the edge.

The user must take into account the risk of injuries when arresting a fall beyond the edge. Special rescue procedures should be introduced and adequate trainings conducted including possibility of a potential fall beyond the edge.

The device AT 403 may be installed only on wooden beams with dimensions of no less than 70x70 mm.

Minimal static strength of a structural anchor point must be 12 kN.

Connect only one device suitable to operate horizontally compliant with EN 353-2, EN 358 or EN 360 to the fixed device in accordance with instruction manual of these devices for such combination.

THE ESSENTIAL PRINCIPLES FOR USERS OF PERSONAL PROTECTIVE EQUIPMENT AGAINST FALLS FROM A HEIGHT

- personal protective equipment shall only be used by a person trained and competent in its safe use.
- personal protective equipment must not be used by a person with medical condition that could affect the safety of the equipment user in normal and emergency use.
- a rescue plan shall be in place to deal with any emergencies that could arise during the work.
- it is forbidden to make any alterations or additions to the equipment without the manufacturer's prior written consent.
- any repair shall only be carried out by equipment manufacturer or his certified representative.
- personal protective equipment shall not be used outside its limitations, or for any purpose other than that for which it is intended.
- personal protective equipment should be a personal issue item.
- before use ensure about the compatibility of items of equipment assembled into a fall arrest system. Periodically check connecting and adjusting of the equipment components to avoid accidental loosening or disconnecting of the components.
- it is forbidden to use combinations of items of equipment in which the safe function of any one item is affected by or interferes with the safe function of another.
- before each use of personal protective equipment it is obligatory to carry out a pre-use check of the equipment, to ensure that it is in a serviceable condition and operates correctly before it is used.
- during pre-use check it is necessary to inspect all elements of the equipment in respect of any damages, excessive wear, corrosion, abrasion, cutting or incorrect acting, especially take into consideration:
 - in full body harnesses and belts - buckles, adjusting elements, attaching points, webbings, seams, loops;
 - in energy absorbers - attaching loops, webbing, seams, casing, connectors;
 - in textile lanyards or lifelines or guidelines - rope, loops, thimbles, connectors, adjusting element, splices;
 - in steel lanyards or lifelines or guidelines - cable, wires, clips, ferrules, loops, thimbles, connectors, adjusting elements;
 - in retractable fall arresters - cable or webbing, retractor and brake proper acting, casing, energy absorber, connector;
 - in guided type fall arresters - body of the fall arrester, sliding function, locking gear acting, rivets and screws, connector, energy absorber;
 - in connectors - main body, rivets, gate, locking gear acting.
- after every 12 months of utilization, personal protective equipment must be withdrawn from use to carry out periodical detailed inspection. The periodic inspection must be carried out by a competent person for periodic inspection. The periodic inspection can be carried out also by the manufacturer or his authorized representative.
- In case of some types of the complex equipment e.g. some types of retractable fall arresters the annual inspection can be carried out only by the manufacturer or his authorized representative.
- regular periodic inspections are the essential for equipment maintenance and the safety of the users which depends upon the continued efficiency and durability of the equipment.
- during periodic inspection it is necessary to check the legibility of the equipment marking.
- it is essential for the safety of the user that if the product is re-sold outside the original country of destination the reseller shall provide instructions for use, for maintenance, for periodic examination and for repair in language of the country in which the product is to be used.
 - representative after carried out the detailed inspection.
- personal protective equipment must be withdrawn from use immediately when any doubt arise about its condition for safe use and not used again until confirmed in writing by equipment manufacturer or his representative.
- personal protective equipment must be withdrawn from use immediately and destroyed when it have been used to arrest a fall.
- a full body harness is the only acceptable body holding device that can be used in a fall arrest system.
- the anchor device or anchor point for the fall arrest system should always be positioned, and the work carried out in such a way, as to minimise both the potential for falls and potential fall distance. The anchor device/point should be placed above the position of the user. The shape and construction of the anchor device/point shall not allowed to self-facting disconnection of the equipment. Minimal static strength of the anchor device/point is 15 kN. It is recommended to use certified and marked structural anchor point complied with EN795.
- it is obligatory to verify the free space required beneath the user at the workplace before each occasion of use the fall arrest system, so that, in the case of a fall, there will be no collision with the ground or other obstacle in the fall path. The required value of the free space should be taken from instruction manual of used equipment.