

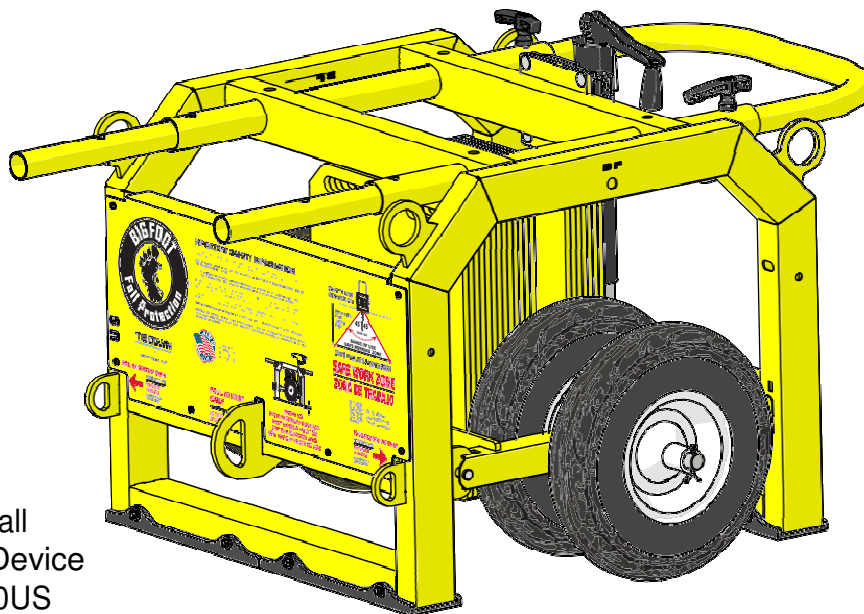

# SAFETY & OPERATIONS MANUAL

**Do not throw away these instructions!**  
**Read and understand these instructions before using this product.**

---



BIGFOOT Fall  
Protection Device  
Model 60060US

Instruction #08333 (E1723 - Rev. 9/16/20)



New in the line of mobile fall arrest systems. The BIGFOOT allows those working on concrete to be tied off safely yet also providing a great deal of mobility.

- Good for one worker in arrest and two in restraint (USA)
- Non penetrating design
- Jack feature makes mobility very easy
- Includes rigging rings for lifting
- Anti-slip design feature
- Premium flat free tires
- Good for concrete, TPO, and EPDM roof material

## Bigfoot Cart Assembly Instructions Model 60060US

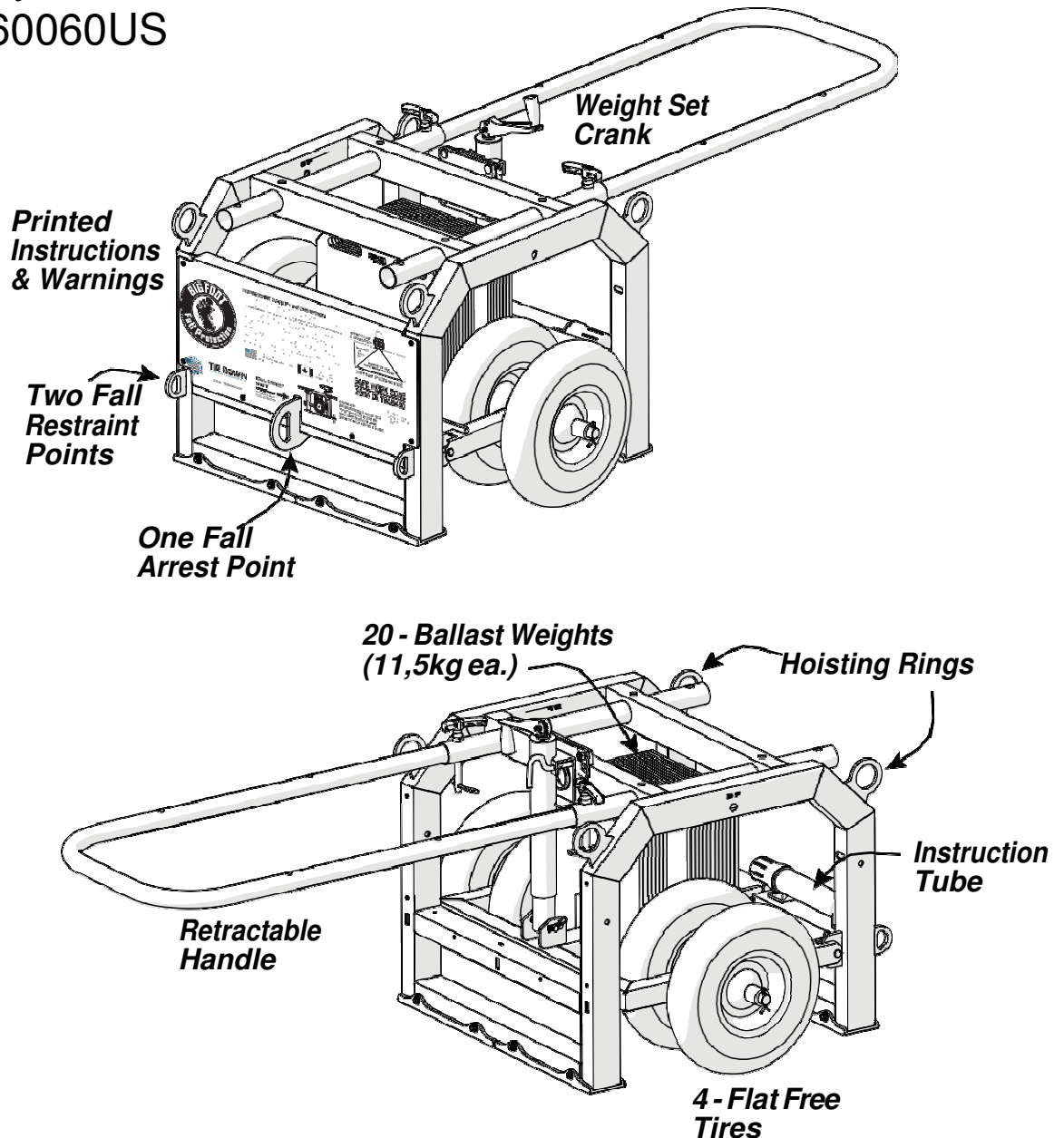

# Installing Ballast Plates

The Bigfoot requires 20 ballast weights to be inserted prior to use.

For safety, the axle spacer automatically distributes the ballast weights.

Place 13 ballast weights on the large side of the axle spacer. Place the remaining 7 ballast weights on the small side of the axle spacer

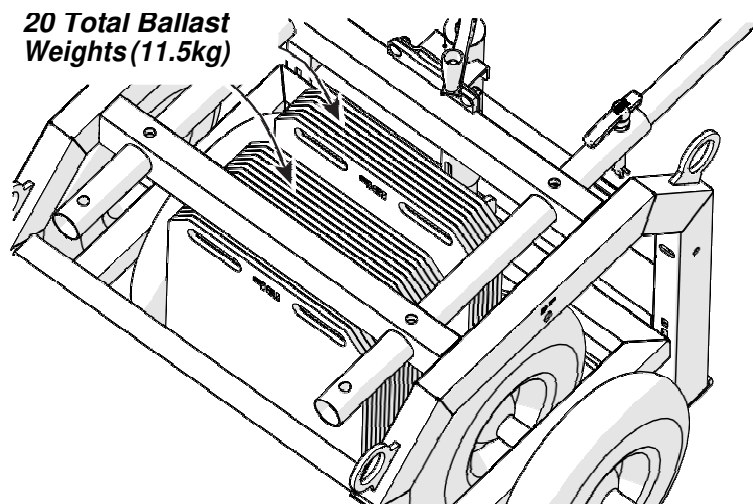
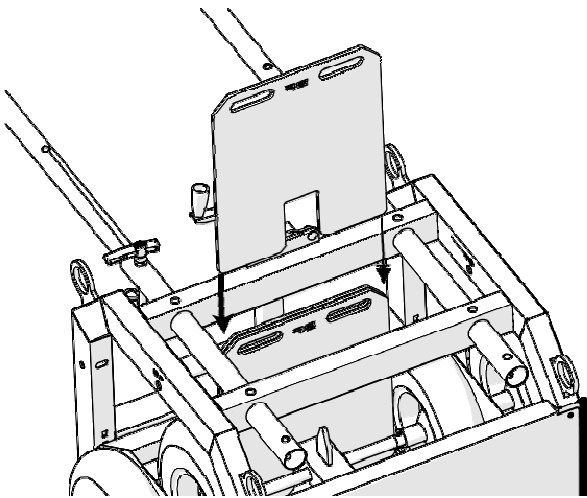
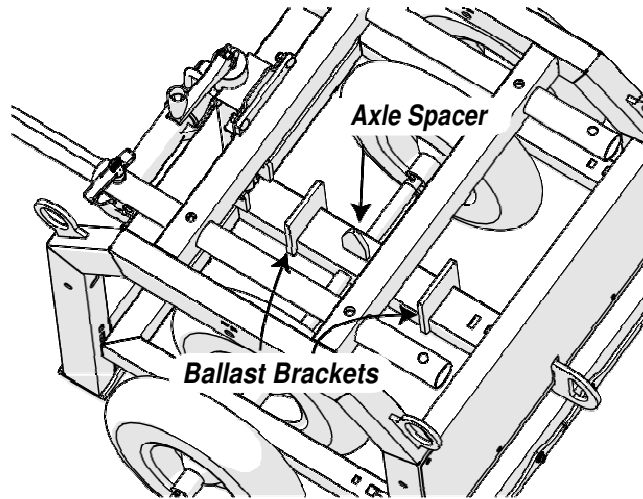

# Set Up

## Secure the Ballast Weights

Once the ballast weights are set use the red safety cable to secure the weights. The red safety cable must pass through all 20 of the ballast weights. Use a lock to secure the cable.

Do not operate the Bigfoot until all 20 weights are placed and the red safety cable is secure.

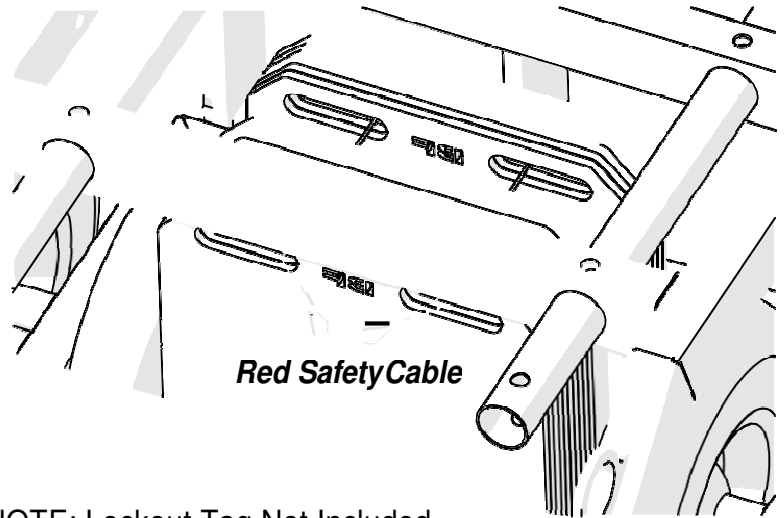

NOTE: Lockout Tag Not Included

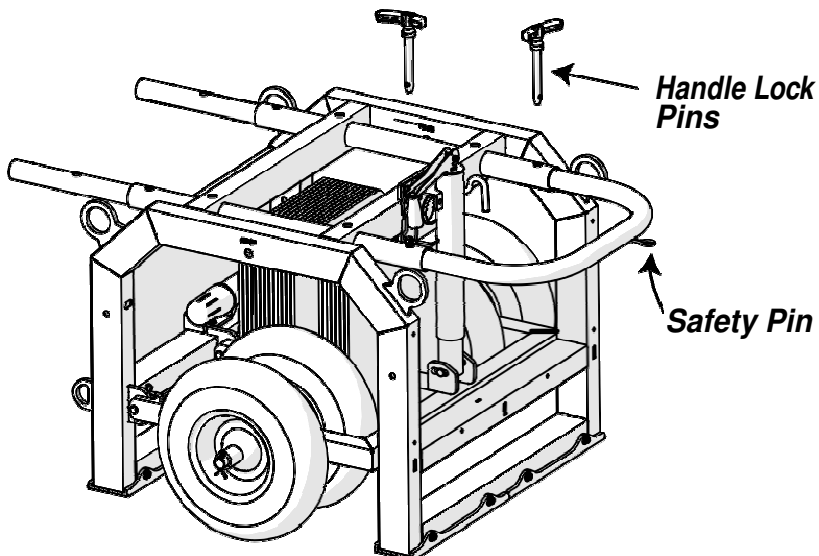

## Extending the Bigfoot Handle

Remove the safety pins from the two handle lock pins located on the top of the U shaped handle.

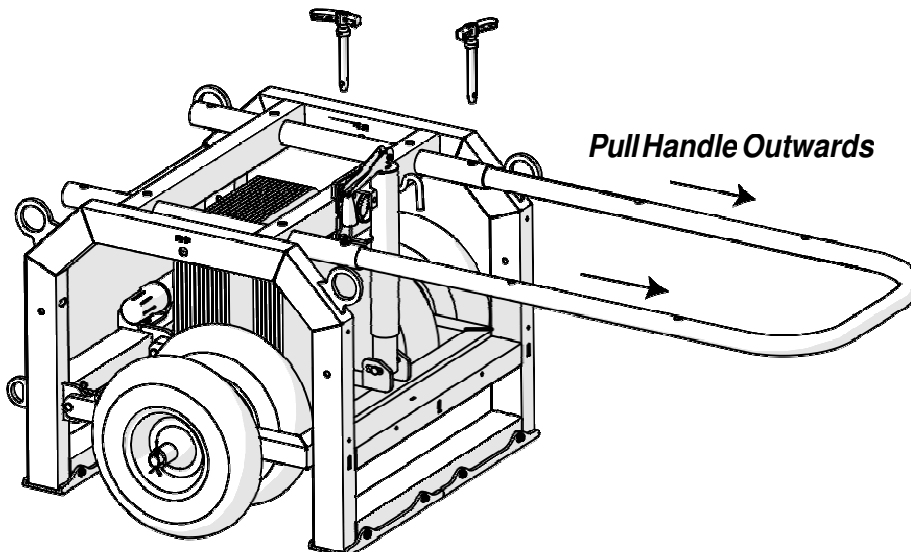

Pull the U shaped handle outward stopping when the last set of mounting holes is visual through the outer handle tube.

Align the handle lock pins with the mounting holes on the handle. Insert the pins and secure with the safety pins through the end of the handle lock pins.

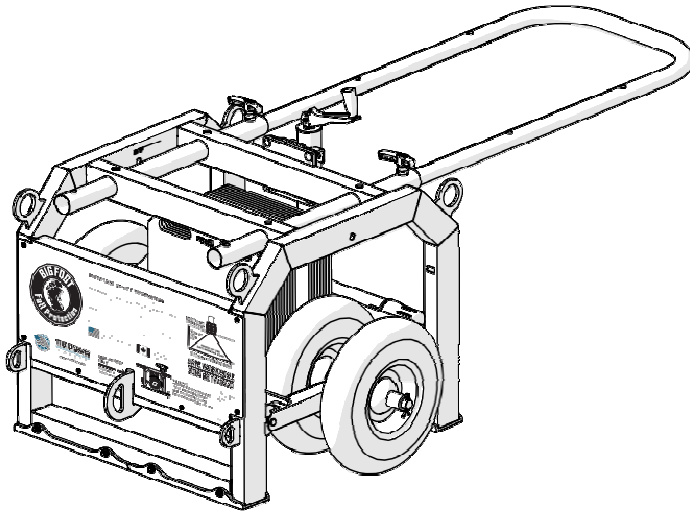

## Applications

When set up properly the BIGFOOT allows for one worker to be tied off for fall arrest and one worker in fall restraint.

**Fall Restraint System** – A fall restraint system (FRS) prevents the user from falling. The system is comprised of a body harness along with an anchorage, connectors and other equipment. The components typically include a lanyard and also may include a lifeline and other devices.

**Personal Fall Arrest System** – A personal fall arrest system (PFAS) arrests a fall after a fall incident has occurred. The system is comprised of an anchor point, connecting device, body harness, connectors, and a body harness and must include a deceleration system, or suitable combinations. Note that a PFAS does NOT prevent a fall from occurring. The BIGFOOT can be used as an anchorage in a PFAS for up to one worker and two in fall arrest. A Personal Fall Arrest System must meet the following requirements:

- Limit maximum arresting force on an employee to 6 kN when used with a body harness;
- Be rigged (lifeline plus deceleration device) so that an employee can neither free-fall more than 1.8 meter nor contact any lower level;
- Bring an employee to a complete stop and limit maximum deceleration distance.
- Have sufficient strength to withstand twice the potential impact energy of an employee free-falling maximum 12kN.

**Anchorage** — An anchorage is a secure point of attachment for lifelines, lanyards, or deceleration devices. The BIGFOOT is a mobile anchorage.

BIGFOOT in Use - Flat Surfaces to slopes up to 1:12.

## Applications: Surfaces

### Recommended Surfaces:

- ✓ Concrete
- ✓ Modified Bitumen Membranes
- ✓ Built-up Roofing (BUR) Membrane
- ✓ Thermoplastic Polyolefin (TPO) Membranes
- ✓ EPDM Roofing Membranes
- ✓ Ballasted EPDM Membrane
- ✓ Flat Surfaces to slopes up to 1:12.

### Do Not Use on the Following Surfaces:

- ✗ Metal Deck less than 0.64 mm.
- ✗ Loose laid material not part of a complete finished system.
- ✗ Ice
- ✗ Snow
- ✗ Tectum Deck
- ✗ Gypsum Deck
- ✗ Modified PVC Membranes
- ✗ Polyisocyanurate (ISO)
- ✗ Expanded Polystyrene (EPS)
- ✗ Hardboard
- ✗ Dens Deck

## Roofing Load Requirements

Before the BIGFOOT is hoisted to any roofing deck the user MUST VERIFY THAT THE DECK CAN ACCOMMODATE THE LOAD REQUIREMENTS OF THE FULL DEVICE – 340 kg.

Verify that the surface that the BIGFOOT will be used on is capable of supporting both the unit and personnel using it. Inspect that the entire area to determine if the working surfaces have the strength and to support users safely.

**CAPACITY:** The BIGFOOT Mobile Fall Protection System is designed for a maximum of one person for fall arrest with a combined weight (clothing, tools) of no more than 150kg per person. “No more than one worker in fall arrest and one worker in restraint can be connected to the BIGFOOT at any time.

**IMPORTANT:** DO NOT start work for which fall protection is required until the BIGFOOT and corresponding Fall Arrest must have been completely installed. Do NOT disable any part of the PFAS, including the BIGFOOT unit, or reposition the unit, until work for which fall protection is required has ceased.

# Placement/Repositioning of the BIGFOOT

Prior to Positioning the BIGFOOT:

Verify that the surface is capable of supporting the BIGFOOT, ballast weights, cart, and all personnel using it.

The attachment tie-off anchor d-rings must be pointed toward the leading edge and the cart is set to travel 90 degrees to the unprotected edge or leading edge.

Position the BIGFOOT such that the front instruction plate is no closer than 2 meters from the leading edge, and in line with the center of the area to be worked.

WHEN REPOSITIONING THE BIGFOOT, ABSOLUTELY NO USERS ARE TO BE ATTACHED TO THE BIGFOOT. USERS MUST MAINTAIN A SAFE DISTANCE OF 8 FT. FROM ANY LEADING EDGE FALL HAZARD.

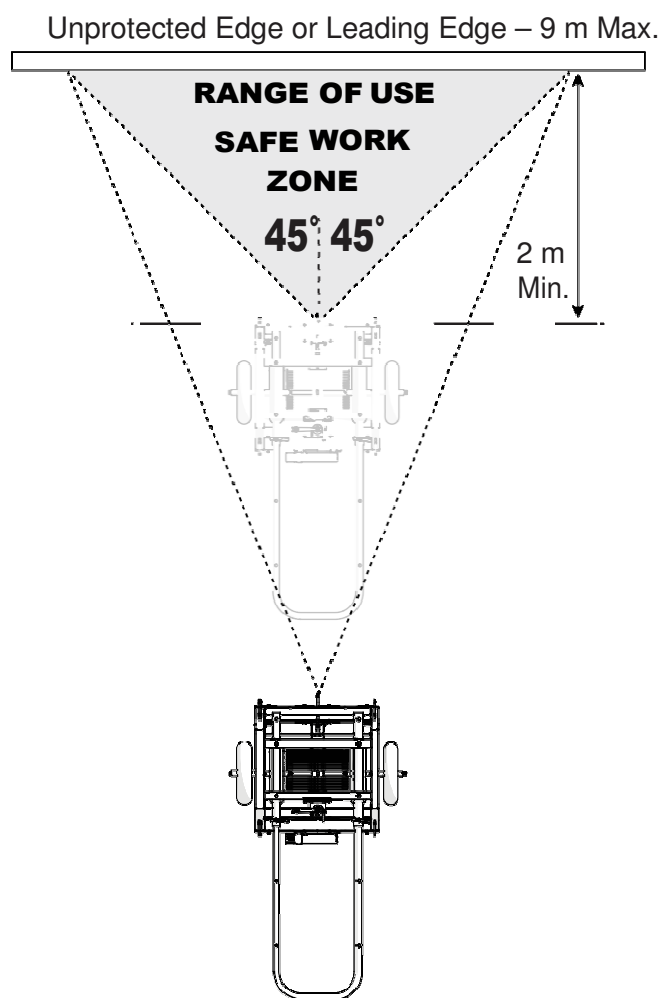
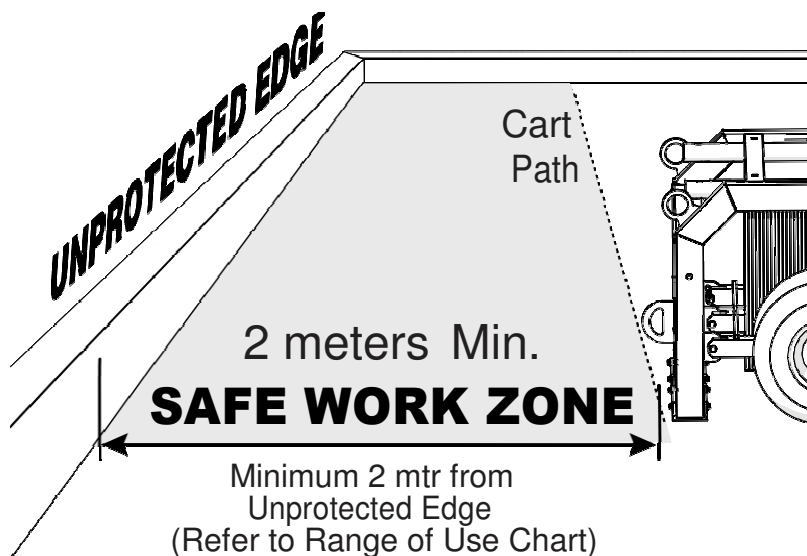

Range of Use Chart

| Distance to Leading Edge | Maximum Range of Use |
|--------------------------|----------------------|
| 2 mtr                    | 5 mtr                |
| 2.5 mtr                  | 5.5 mtr              |
| 3 mtr                    | 6 mtr                |
| 3.3 mtr                  | 6.5 mtr              |
| 3.6 mtr                  | 7 mtr                |
| 3.9 mtr                  | 7.8 mtr              |
| 4 mtr                    | 8.5 mtr              |
| 4.5 mtr                  | 9 mtr                |

After 4.5mtr Max. Range  
No Greater than 9 mtr

## Setting the Ballast Weight

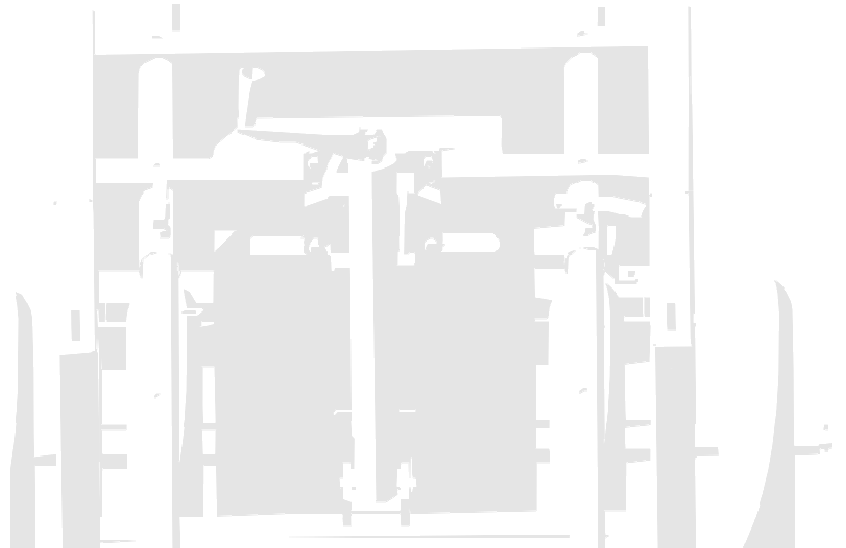
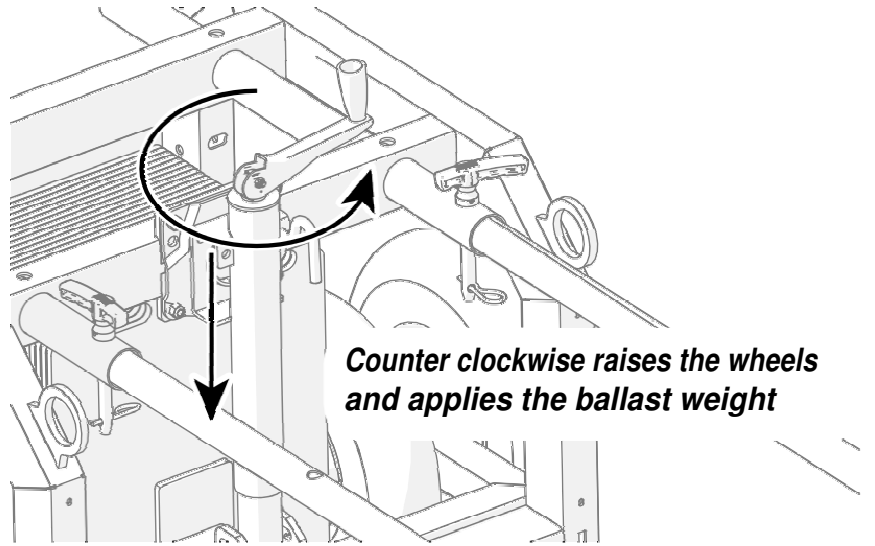



## Connecting to the BIGFOOT

DO NOT hook Personal Fall Arrest System (PFAS) to any point except a Fall Arrest or Fall Restraint Anchor D-ring.

When making connections, only use double-locking snap hooks and double-locking carabiners with this equipment. Only use connectors that are suitable to each application. Ensure all connections are compatible in size, shape and strength. Do not use equipment that is not compatible. Ensure that all connectors are fully closed and locked.

### Fall Arrest Tie-Off D-ring

The one fall arrest tie off D-ring is located on the lower center of the BIGFOOT. The user must insure that the lanyards and harness are properly attached.

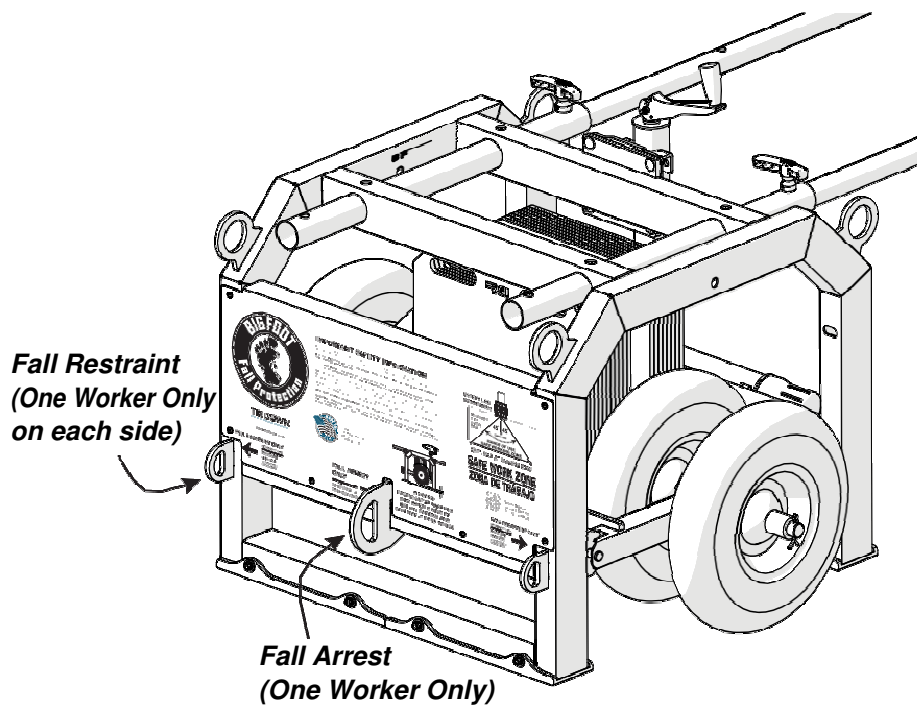

## Before Using the BIGFOOT

OSHA requires that before operating the system there must be an inspection for damaged equipment.

- 1 Check for loose, bent or damaged parts.
- 2 Check welded components for distortion, cracks, or other damage.
- 3 Check D-rings for distortion or damage replace if needed.
- 4 Check the slide handle for rusting and/or wear before each use.
- 5 All labels must be present and fully legible. (Copies of all labels are show on page 12)
- 6 Check for all pull pins that they are fully inserted and the safety cotter pin clips are attached to each pull pin.

**IMPORTANT: BEFORE USING THIS UNIT, A RESCUE PLAN MUST BE ADOPTED.**

OSHA requires employers to provide a quick rescue of employees in the event of a fall or employers shall assure that employees are able to rescue themselves. It is impossible to guarantee that an employee can rescue himself because he may be unconscious or injured as a cause or result of the fall. Therefore, a procedure involving rescuers must be adopted.

Consult with your roofing distributor/supplier for fall rescue equipment.

**DONOT OPERATE DAMAGED EQUIPMENT. DONOT OPERATE EQUIPMENT THAT HAS BEEN MODIFIED.**  
(Please use the Inspection and Maintenance Log contained within the instructions manual )

## Maintenance and Care

- ✓ Inspect BIGFOOT before and after each use.
- ✓ Keep wheels free from debris.
- ✓ Regularly inspect for damaged or missing parts and do not place the BIGFOOT into service until all missing and or damaged parts have been replaced.
- ✓ Store the BIGFOOT in a place protected from weather and where only authorized employees have access.
- ✓ Maintain finish to prevent corrosion.

## General Safety Precautions

**USE COMMON SENSE!** Most accidents can be avoided by using common sense and concentrating on the job at hand. Look around and confirm a safe distance from the roof edge is being maintained.

The BIGFOOT should not be used by persons whose ability or alertness is impaired by fatigue, intoxicating beverages, illegal or prescription drugs, or any other physical cause that exposes the user or others to injury.

Always wear proper safety attire.

Keep hands and feet clear of moving parts. **DO NOT** stick hands or fingers in the equipment when workers are attached to the BIGFOOT.

Do not operate the equipment near electrical power lines. **ELECTRICITY KILLS!**

## General Safety Precautions

Ensure that all areas directly underneath, and in front of the cart, are clear and free of debris.

Do not use on roofs with ice or snow.

Only use the unit on a surface or roof composition for which it has been tested.

Do not set unit atop unfastened materials. Materials may slide if not mechanically attached to the roof.

## Hoisting Safety Precautions

Loads may slip, if the BIGFOOT is not hoisted properly, this could result in injury or death.

Do not use with damaged slings or chains.

Utilize appropriate rigging gear for overhead lifting.

Utilize rigging gear within the industry standards and the manufacturer's recommendations.

Conduct regular inspection and maintenance of the rigging gear.

DO NOT hook to the fall arrest or fall restrain safety line connectors when lifting the cart.

## Procedure for Handling the BIGFOOT After a Fall

Before rescuing a fallen employee, check that the BIGFOOT is secure.

It is highly recommended that any rescuer be tied off in a FRS before attempting to aid in a rescue. The number of rescuers allowed to tie off to the BIGFOOT is 1 (one).

# Replacement Labels

**WARNING**  
DONOT CONNECT ANY FALL PROTECTION TO THE HOISTING RINGS

#15802  
Rev. 12/18

Tag #15802  
One on Each Ring

**ADVERTENCIA**  
NO CONECTE NINGUNA PROTECCIÓN CONTRA LA CAÍDA A LOS ANILLOS DE ELECCIÓN

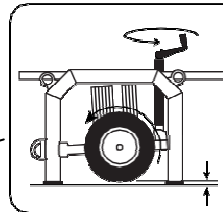

**WARNING**  
PROPER SETUP REQUIRES THAT WHEELS MUST BE OFF THE SURFACE AND SPIN FREELY PRIOR TO USE

Label #15239

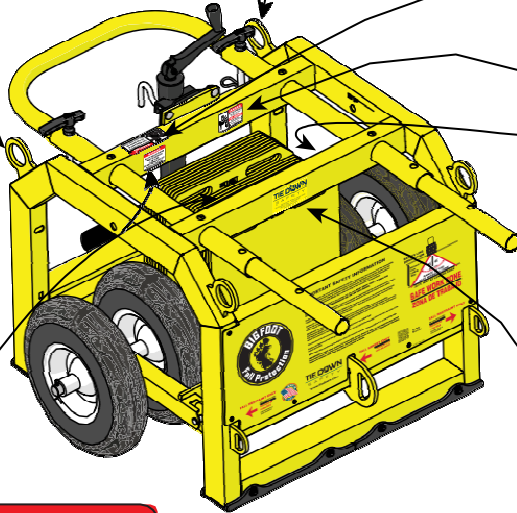

**DANGER**  
**PINCH POINT**  
Keep hands clear of this area!  
**PELIGRO**  
PUNTOS DE AJUSTAMIENTO  
Cuidado con Las Manos

Label #15183

**WARNING**  
ALL 20 BALLAST PLATES MUST BE INSTALLED PRIOR TO USE. DO NOT REMOVE BALLAST PLATES WHILE IN USE.

Label #15238

**EYECATCHER**  
Height Safety Systems

Eyecatcher BV - Candelastraat 2 - 2441LR Nieuveen  
www.eyecatchersafety.com

Label #15824

**TIE DOWN SAFETY**  
www.tiedown.com

**IMPORTANT SAFETY INFORMATION**

Always refer to the safety manual. It contains important information for proper use of the equipment. It is the user's responsibility to read and understand the safety manual and to follow the instructions carefully. The user must also read the instructions for the equipment and the instructions for the fall protection equipment. The user must also read the instructions for the fall protection equipment. The user must also read the instructions for the fall protection equipment.

Before the equipment can be located to any location, the user MUST VERIFY THAT THE EQUIPMENT CAN BE USED AT THE LOCATION AND UNDER THE CONDITIONS OF USE.

The equipment is not intended for use on uneven surfaces. The user must verify that the equipment can be used on the intended surface. The user must also verify that the equipment can be used on the intended surface. The user must also verify that the equipment can be used on the intended surface.

**WARNING:** When positioning the equipment, the user must verify that the equipment can be used on the intended surface. The user must also verify that the equipment can be used on the intended surface. The user must also verify that the equipment can be used on the intended surface.

**WARNING:** DO NOT allow anyone to cross paths between the equipment and the intended fall protection equipment. Always use the correct number of safety lines and always use the correct number of safety lines. Do not use the equipment on the intended surface unless it is specifically designed for that purpose.

**SAFETY LINE CONNECTION**

30 FT. MAX AT LEADING EDGE  
**SAFE WORK ZONE**  
**ZONA DE TRABAJO**

**FALL RESTRAINT ONLY**  
DO NOT FALL SAFETY LINES  
Restricción de caídas SOLO  
RESTRICCIÓN DE LA CAÍDA SOLAMENTE

**FALL ARREST ONLY**  
DEFIENCIÓN DE LA CAÍDA SOLAMENTE

**WARNING:**  
PROPER SETUP REQUIRES THAT WHEELS MUST BE OFF THE SURFACE AND SPIN FREELY PRIOR TO USE

**FALL RESTRAINT ONLY**  
DO NOT FALL SAFETY LINES  
Restricción de caídas SOLO  
RESTRICCIÓN DE LA CAÍDA SOLAMENTE

## BIGFOOT FALL PROTECTION LIMITED WARRANTY

Eyecatcher(TIE DOWN) will repair or replace, free of charge, any part, or parts of the Bigfoot Fall Protection Device that are defective in material or workmanship or both. The limited warranty is in effect for 90 days from date of purchase. Return the defective unit to the dealer or contact Eyecatcher BV at 0031 172 575 570.

This warranty does not apply to damage or loss caused by any or all of the following circumstances or conditions:

- Damage caused during assembly or installation.
- Parts, accessories, materials or components used with or replacing any BIGFOOT part not obtained from or approved in writing by Eyecatcher BV.
- Misapplication, misuse and failure to follow the directions or observe cautions and warnings on installation, operation, application, inspection or maintenance specified in any Eyecatcher quotation, acknowledgment, sales literature, specification sheet or installation instruction and service manual ("applicable literature").
- Use of product in any other application other than those described in Eyecatcher's product information materials.

If any EYECATCHER products are found upon Eyecatcher's examination to have been defective when supplied, EYECATCHER will either: credit the purchaser's account for the purchase price of the EYECATCHER product; replace the EYECATCHER product; or repair the product. EYECATCHER has sole discretion in choosing which option to provide. For this LIMITED WARRANTY to apply, EYECATCHER must receive notice of the alleged defect within 30 days of either the discovery of the alleged defect or the expiration of the warranty period, whichever is earlier. Any claim not made within this period shall conclusively be deemed waived.

If requested by TIE DOWN, purchaser shall return the alleged defective product to EYECATCHER for examination at purchaser's expense. EYECATCHER will not pay for expenses incurred in returning a product to EYECATCHER without Eyecatcher's prior written authority. EYECATCHER shall not be liable for any other expenses purchaser incurs to remedy any defect. Purchasers waive subrogation on all claims under any insurance.

**Limitation of Liability:** It is expressly agreed that the liability of EYECATCHER is limited and EYECATCHER does not function as an insurer. THE REMEDIES SET FORTH IN THIS WARRANTY SHALL CONSTITUTE THE EXCLUSIVE REMEDIES AVAILABLE TO THE PURCHASER OR USER AND ARE IN LIEU OF ALL OTHER REMEDIES, EXPRESS OR IMPLIED. THE LIABILITY OF TIE DOWN, WHETHER IN CONTRACT, IN TORT, UNDER ANY WARRANTY OR OTHERWISE, SHALL NOT EXCEED THE PURCHASE PRICE OF THE PARTICULAR PRODUCT MANUFACTURED, SOLD OR SUPPLIED BY TIE DOWN.

**To Obtain Technical Assistance:** To enable EYECATCHER to respond to a request for assistance or evaluation of customer or user operating difficulty, please provide at a minimum the following information by calling 404-344-0000:

- Model number, serial number and all other data on the specific component which appears to be involved in the difficulty.
- The date and from whom you purchased your EYECATCHER product.
- State your difficulty, being sure to mention at least the following: Application, Environment, Working Surface, and Number of Workers.

THIS WARRANTY DOES NOT COVER NOR EXTEND TO INCIDENTAL OR CONSEQUENTIAL DAMAGE. Some states do not allow the exclusion or limitation of incidental or consequential damages, so the above limitation or exclusion may not apply to you. This warranty gives you specific legal rights, and you may also have other rights which vary from state to state.

No representative has authority to make any representation, promise or agreement except as stated in this Limited Warranty. EYECATCHER reserves the right to make design and other changes upon its products without any obligation to install the same on any previously sold or delivered products.

THERE ARE NO WARRANTIES WHICH EXTEND BEYOND THOSE DESCRIBED ABOVE. EFFECTIVE MAY 2017 THIS WARRANTY SUPERSEDES ALL PRIOR WARRANTIES, WRITTEN OR IMPLIED.

# DECLARATION OF CONFORMITY

Declaration Date: 04.21.2020

Internal Reference Document: ITR-60060US\_R1

Rev. 1

|  |   |
|--|---|
| <b>DECLARATION NO.</b>   | SUW-5055811-TRF-01  |
| <b>PART NUMBER:</b>  | 60060US   |
| <b>PART DESCRIPTION:</b>   | Big Foot  |
| <b>TEST SPECIFICATION(S):</b>  | OSHA 1926 <ul style="list-style-type: none"><li>• Successfully pass a drop test with a 310 lb. test weight.</li></ul> ANSI Z359.6 <ul style="list-style-type: none"><li>• Dynamic or energy analysis of ballasted anchorages.</li></ul> EN-795:2012 type E <ul style="list-style-type: none"><li>• Dynamic and static tests 12kN.</li></ul> |
| <b><u>ADDITIONAL INFORMATION REGARDING THIS DOCUMENT OR STANDARD(S) EVALUATED:</u></b> |   |

**EYECATCHERENGINEERING** DECLARES THAT THE PRODUCT(S) LISTED ABOVE IS IN CONFORMITY WITH THE REQUIREMENTS OF THE FOLLOWING PERFORMANCE STANDARDS.

|   |
|---|
| <b>STANDARD(S):</b>   |
| <ul style="list-style-type: none"><li>• OSHA 1926 Fall Protection Criteria</li><li>• ANSI / ASSE Z359.6-2016 Specifications and Design Requirements for Active Fall Protection Systems</li><li>• EN-795:2012 type E</li></ul> |

**AUTHORIZED BY:**

| <b>NAME</b>      | <b>TITLE</b>                       | <b>DATE</b> |
|------------------|------------------------------------|-------------|
| WILSON HA        | ENGINEER                           | 2020-21-04  |
| TRAVIS TURNER    | ENGINEERING MANAGER                | 2020-21-04  |
| SLOAN MACKARVICH | CHIEF BUSINESS DEVELOPMENT OFFICER | 2020-21-04  |

This Certificate is a guarantee that the above standard(s) was met by the requirements of such standard. Testing was performed under normal operation mode. The results of testing apply only to the particular sample tested and to the specific test carried out. This Certificate is only issued for products which have passed the testing requirements of listed standard(s).

## Test Report

|                                     |                          |
|-------------------------------------|--------------------------|
| <b>Test Operator(s):</b>            | Wilson Ha, Travis Turner |
| <b>Test Date:</b>                   | 3/24/2020                |
| <b>Part Number:</b>                 | 60060US                  |
| <b>Part Revision:</b>               | 1                        |
| <b>Internal Test Report:</b>        | ITR-60060US_R1           |
| <b>Third Party (if applicable):</b> |                          |

## Test Summary

| Test Specification                 | Test Criteria   | Test Result |
|------------------------------------|---|-------------|
| OSHA 1926.502                      | <ul style="list-style-type: none"> <li>• Drop test, using a 310 lb. test weight and 6ft. PEA lanyard.</li> <li>• Must have sufficient strength to withstand twice the potential impact energy of an employee free falling a distance of 6 feet (1.8 m), or the free fall distance permitted by the system, whichever is less.</li> <li>• Test weight must not hit the ground</li> </ul>   | PASS        |
| ANSI Z359.6<br>Clauses: 4.6.10.3.1 | <ul style="list-style-type: none"> <li>• Using dynamic or energy analysis to determine the proper distance the ballasted anchorage must be away from the leading edge for safe use.</li> <li>• The closest edge of the anchorage connector shall be located a distance from the unprotected edge that is at least 2 times the calculated distance that the anchorage connector will slide before the fall has been arrested or 8 feet, whichever is greater.</li> </ul> | PASS        |
| EN-795:2012 type E                 | <ul style="list-style-type: none"> <li>• Dynamic drop test with 100 kg load to generate impact force of 9 kN on dry and wet surface, directly followed by pull force of 300 kg for 3 minutes.</li> <li>• Horizontal displacement &lt; 70cm.</li> <li>• Static test 12 kN on dry and wet surface for 3 minutes.</li> </ul>   | PASS        |

### Conclusion

- **Weight of Big Foot ~340 kg.**
- **Max 1 worker in fall arrest per unit.**
- **Max 1 worker in fall restraint per unit**
- **Per the EN-795 standard, the minimum distance the product should be setup is 2 meter from the leading edge.**



# Inspection Checklist and Maintenance Log

BIGFOOT Model # \_\_\_\_\_ Date of Purchase: \_\_\_\_\_  
 Serial Number: \_\_\_\_\_ Purchased From: \_\_\_\_\_

| BIGFOOT Cart                                    | Date: |  |  |  |  |  |  |  |  |
|---|-------|--|--|--|--|--|--|--|--|
| Frame: Free of Rust?                            |       |  |  |  |  |  |  |  |  |
| Frame: Welded Connections?                      |       |  |  |  |  |  |  |  |  |
| Axles/Wheels Rotate Properly?                   |       |  |  |  |  |  |  |  |  |
| Overall Cart Parts?                             |       |  |  |  |  |  |  |  |  |
| Handle Pins (2)?                                |       |  |  |  |  |  |  |  |  |
| Handle Moves in and Out Smoothly?               |       |  |  |  |  |  |  |  |  |
| Ballast: All 20 Installed?                      |       |  |  |  |  |  |  |  |  |
| Ballast Cable Secured w/plates and Locked       |       |  |  |  |  |  |  |  |  |
| Is the Instruction Cover Plate Fully Readable?  |       |  |  |  |  |  |  |  |  |
| Instructions Are Available in Instruction Tube? |       |  |  |  |  |  |  |  |  |
| Are the Warning Labels Fully Readable?          |       |  |  |  |  |  |  |  |  |
| Does the Crank Handle Work Properly?            |       |  |  |  |  |  |  |  |  |
| Are the Anti Skid Pads Cracked or Worn?         |       |  |  |  |  |  |  |  |  |
|   |       |  |  |  |  |  |  |  |  |
|   |       |  |  |  |  |  |  |  |  |
|   |       |  |  |  |  |  |  |  |  |

Date                      Corrective Action Taken:

---



---



---



---



Eyecatcher BV  
 Candelastraat 2  
 2441 LR Nieuwveen  
 The Netherlands  
 www.eyecatchersafety.com  
 E: info@eyecatchersafety.com  
 T: 0031 172 575 570